

Junttan

Pile Driving Rig

PM 30

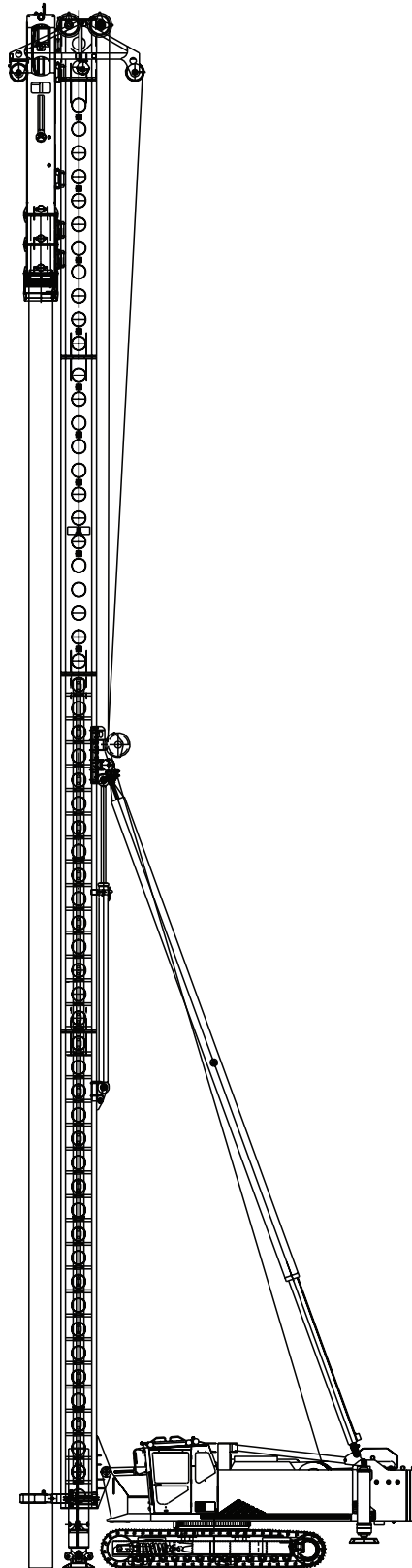

Original
Junttan
product

DATA SHEET

General Information

Junttan PM 30 is a heavy-duty piling rig designed for pile driving where steel or concrete piles are long and heavy. The recommended hammer ram weight is from 6 000 to 12 000 kg and the maximum pile length is 36 meters (118 ft). The rig has proven productivity due to top pile driving performance with Junttan hydraulic hammers. An optional side drill or vibrator hammer makes pile driving even more efficient in some soil conditions. With optional Junttan equipment, optimised working set-up of the rig can be easily achieved.

This Junttan piling rig has the same proven features as the smaller Junttan machines. Its rugged design makes it a safe and reliable rig even in the most demanding working conditions. The selferecting leader and many advanced technical features ensure that the rig is ready to work in just a few minutes. The ergonomic and safety tested cabin allows the driver to concentrate completely on his work. The expandable tracks and low centre of gravity make the rig exceptionally stable in different working situations. The horizontal movement of the leader ensures fast spotting of the pile.

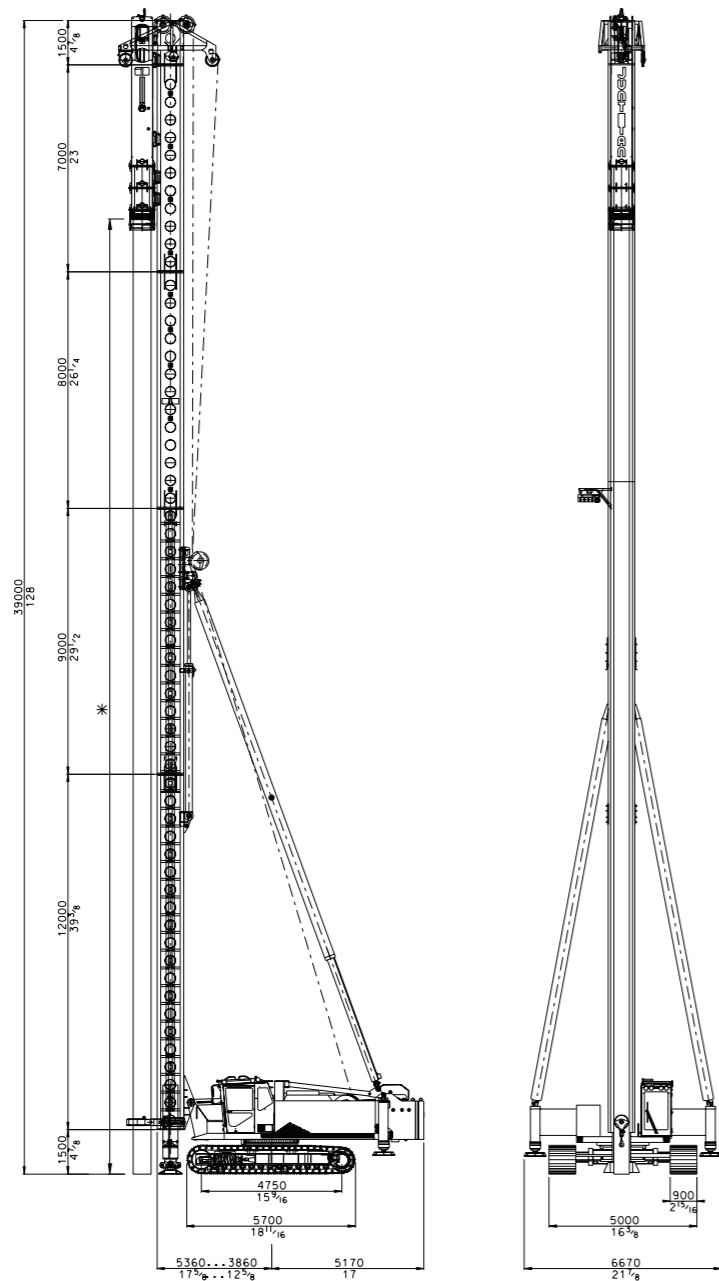

* Pile length depends on the hammer.

Technical Data

Basic features

Nominal operational weight		110 000 kg	242 500 lb
Leader capacity		35 000kg	77 200 lb
Winch capacity	Pile:	12 000 kg	26 500 lb
	Hammer:	20 000kg	44 100 lb
	Auxiliary:	5 000 kg	11 000 lb
Recommended hammer type		HHK6-HHK12	HHK6-HHK12
Maximum pile length (HHK9A/HHK12A)		32 m	105 ft

Uppercarriage

Type	Junttan PM30		
Engine	Type:	Cummins QSM11	
	Power:	280 kW	376 hp
	Fuel tank:	850 liters	225 gal
Hydraulic system	Max flow:	2x280 + 120 lpm/2000rpm	2x74 + 32 gpm/2 000rpm
	Max pressure:	320 bar	4 640 psi
	Cooling system:	2xT8 coolers	2xT8 coolers
	Oil tank:	1 100 liters	290 gal
Counterweight	Extendable:	20 000 kg	44 100 lb
Stabilizers	Included		

Leader

Type	Fixed PM30		
Movements	Foot stroke	1 500 mm	59 in
	Horizontal	1 500 mm	59 in
Inclinations	According separate capacity tables Electronic inclinometer included		

Undercarriage

Type	JV57160HD		
Crawler length	5 700 mm		225 in
Crawler type	D7E		
Width (900 shoes)	Min:	3 500 mm	138 in
	Max:	5 000mm	197 in
Track shoe options	Width:	800/900/1 000 mm	31 1/2/35 1/2/39 1/2 in
	Surface:	3-edge / flat edges / flat	
	Edge type:	normal / chamfer / bended	

Accessories

* iPiler PCD		* Air conditioning
* Side auger	JD3	* Auxiliary winch (5 000kg / 11 000 lb)

* Contact Junttan sales for all available options and accessories

Transport Dimension

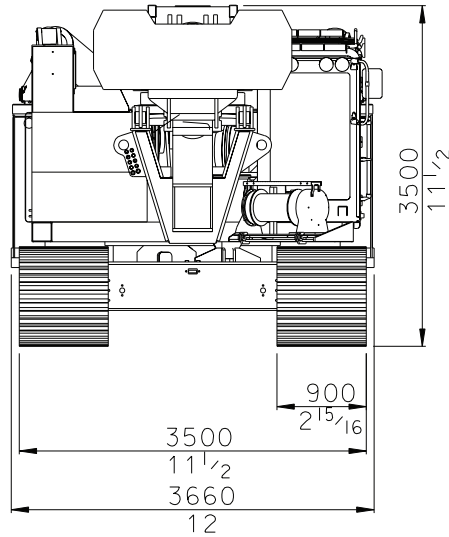

Minimum track width.

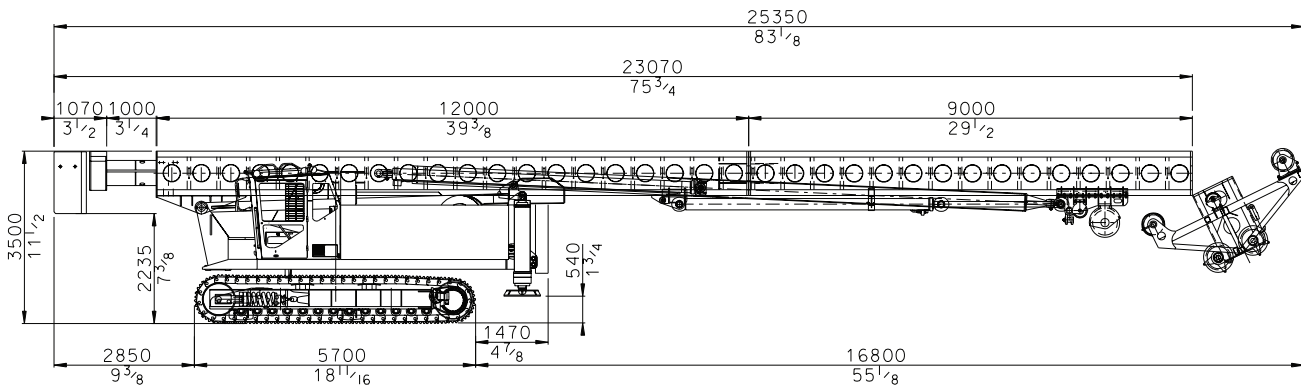

Standard PM 30 transport dimensions.

Junttan

Junttan Oy
P.O. Box 1702 (Matkusentie 7)
FI-70701 KUOPIO, Finland

Tel. +358 10 195 221
Fax +358 17 287 4411
junttan@junttan.com