



GERENUK 500 Multilifter



The most intelligent remote controlled multi-lifter in the industry. It can be adapted to all telescopic loaders, cranes and lifting gear to lift most known building materials.

Unique handling, safety and service features:



3D Manipulation

The strong, and extremely precise head, on which the front system is mounted, has a sturdy design which allows the front system to rotate and tilt the elements in all directions. Consequently, the mounting options are almost unlimited.

The ability to manipulate materials 360° in all directions is truly unique. You can approach the mounting area from any angle and adapt the load with the 3D feature. It is truly second to none.



2 x 200% Overcapacity

A two-circuit vacuum system ensures that the suction discs always have 2 x 200% overcapacity. A visual - and an acoustic alarm ensure that the machine is not operated until the system has reached optimum suction power.



Millimeter Precision

With the Gerenuk@500/1100, building materials are handled with precision to the millimeter thanks to the full pressure hydraulic system with radio remote control allowing optimum visibility and safest proximity for the operator.



Unique Adaptability

The Gerenuk 500 can lift almost any building material, due to specially adapted suction cups. Optional cups are available for porous materials like wood or drywall, as well as for rough surfaces like granite.



Remote Service

The Gerenuk 500 can go online and be serviced remotely; enabling speedy diagnostics, remote programming and tailored repairs. The on-board computer supervises all systems and reports any damage.

Pick, Carry & Install Job Site Building Materials



Granite



Wood

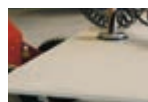

Drywall



Steel



Concrete



Wall panels



Glass



Global Lift Group
www.globalliftgroup.com
sales@globalliftgroup.com

North American Head Office
Delaware, ON Canada N0L 1E0
Phone: 1.855.779.3371

European Head Office
DK - 9640 Farsøe Denmark
Phone: 45 75727215

GLOBAL LIFT GROUP



Technical Specifications

Description	Value
Loading capacity	1100 lbs, 500 kg
Own weight	1584 lbs, 720 kg
Adaptor weight	Type specific
Machine min. width	43 in, 1100 mm
Machine min. depth	35 in, 900 mm
Machine min. height	69 in, 1750 mm
Autonomy	8 hours
Side shift	8 in, 200 mm
Telescopic arm	17 in, 420 mm
Charging current	220 or 110 V
Battery specs.	2 x 152 Ah / 24 V
Charging time	10-100 % - 8 hours
Charging time	25-70 % - 1 hour

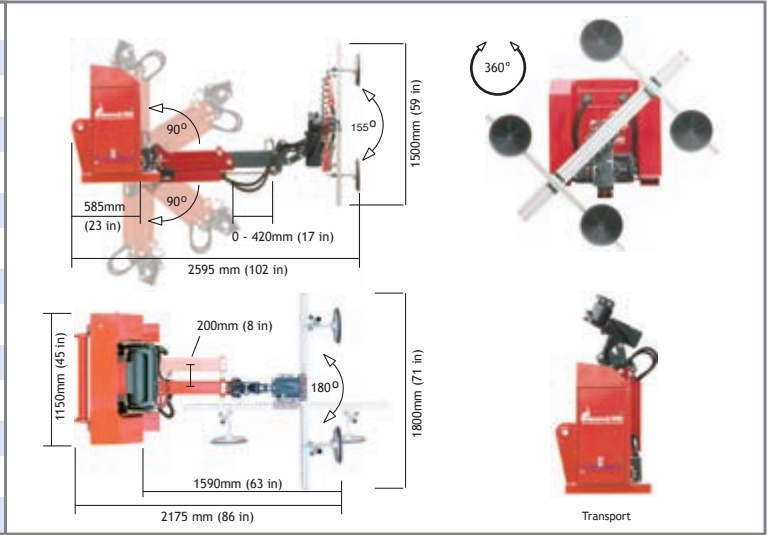

Range

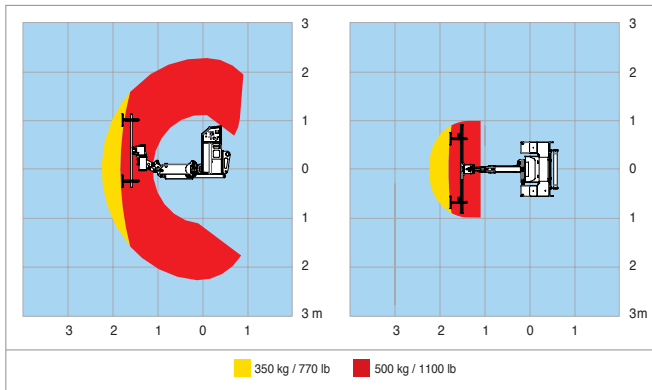

Special construction of the Gerenuk allows fitting of windows and doors on balconies from the outside.

Unique Adaptability

Mount the Gerenuk on any host machine already in your possession.

Mount building materials from 0 to 100m (328 ft).



Standards

Our machines comply with the requirements of Machinery Directive 2006/42/EC, and are ASME B30.5, 5-1.1, 5-1.10 Compliant, ASME B30.20 Compliant, SAE-J1063 Compliant, and SAE-J765 Compliant. Other standards met include EN ISO 14121-1, EN ISO 12100-1, EN ISO 12100-2, EN 13155, EN 982. Our manufacturing facility is ISO9001 certified.



Global Lift Group
www.globalliftgroup.com
sales@globalliftgroup.com

North American Head Office
Delaware, ON Canada N0L 1E0
Phone: 1.855.779.3371

European Head Office
DK - 9640 Farsøe Denmark
Phone: 45 75727215

