

CHASSIS

A

GLG 360 MP

Very powerful medium all adaptable glass handler lifting up to 360 kg/794 lbs.



Foam filled no flat tires

- Intelligent all adaptable glass handler for millimeter precise maneuverability of flat materials
- No Outriggers - less floor space required
- Drives through narrow passages down to 62,5 cm/25"

400% overcapacity



The most secure vacuum system with two separate 200% systems.

All-hydraulic

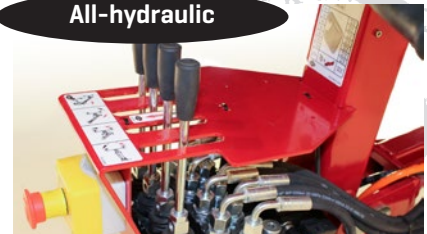

All moving parts are controlled by the powerful and extremely precise hydraulic system.

Choose 1 or 2 batteries



The powerful battery solution ensures optimal autonomy and recharges over night.

Millimeter precise

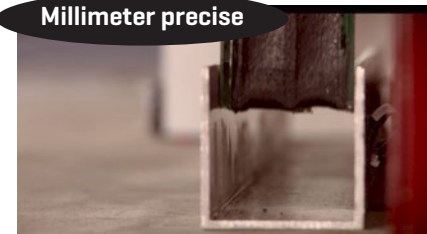

The GLG all adaptable handlers are the most precise lifters in the world when combined with the extremely heavy loads.

SERVICE
24 HOUR
DELIVERY OF SPARE PARTS



We lift it up where it belongs!

www.glgsales.com



Technical specifications

Description	EU	US	Description	EU	US
Loading capacity w. 20 counterw.	360 kg	794 lb	Width min	625 mm	25"
Own weight w. counterw.	652 kg	1437 lb	Width max	833 mm	33"
Own weight without counterw.	463 kg	1021 lb	Width twin wheels	1.083 mm	43"
Axle load rear	243,00 kg	536 lb	Width boom	1.200 mm	47"
Axle load front	220,00 kg	485 lb	Length min.	2.000 mm	79"
Pressure rear wheels	4,31 kg/cm ²	4,31 kg/cm ²	Sideshift	70 mm	3"
Pressure front wheels	3,49 kg/cm ²	3,49 kg/cm ²	Vertical shift	150 mm	6"
Pressure front wheels twin mount	1,44 kg/cm ²	20,5 lb/in ²	Charging current	115 V/230 V	
Max lifting height	2.063 mm	81"	Battery [std.]	12 V / 159AH	
Height min	1.300 mm	51"	Autonomy	10 hours	
			Charging time 30% to 100%	App. 9 hours	

Lifting diagramme

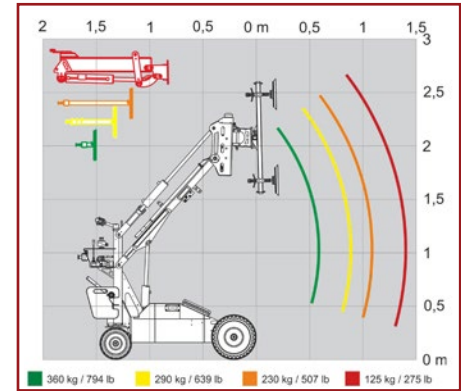

Lifting data with the different extension arms and with the front lift arm.

Measurements

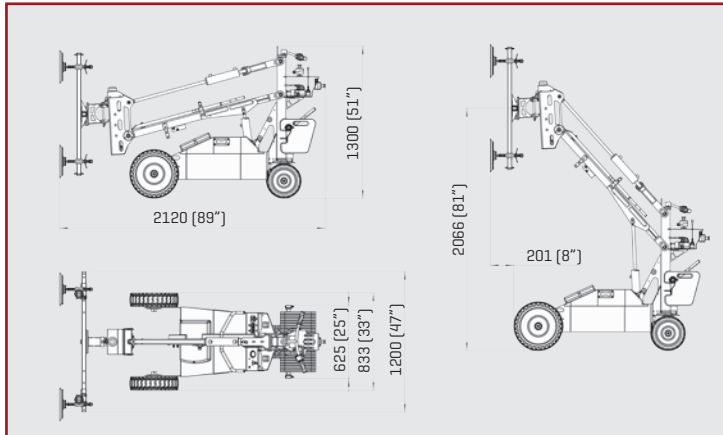

Accessories

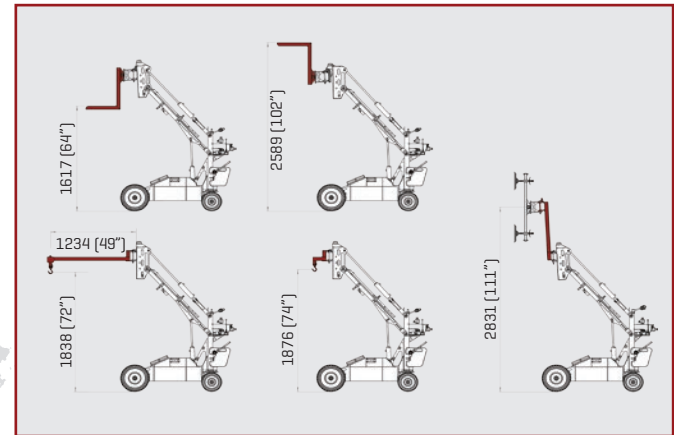

Front wheel set-up's

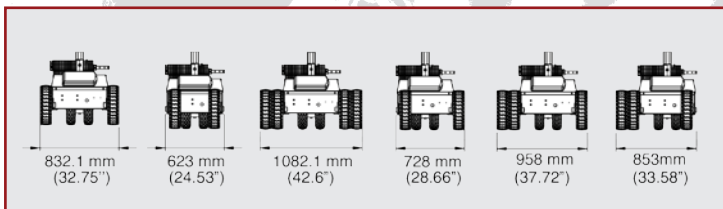

Horizontal lifting arm

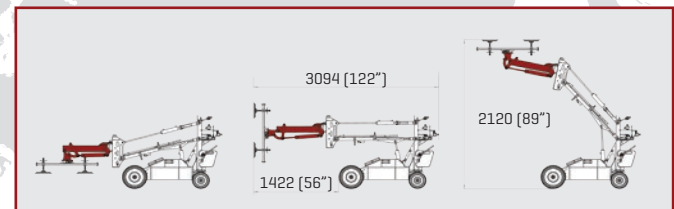

Specifications Our machines comply with the requirements of Machinery Directive 2006/42/EC, and are ASME B30.5, 5-1.1, 5-1.10 Compliant, ASME B30.20 Compliant, SAE-J1063 Compliant, and SAE-J765 Compliant.

Other standards met include:
 DS/EN ISO 12100:2011 Safety of machinery – General principles for design
 DS/EN ISO 4413:2010 Hydraulic fluid power
 DS/EN 13155 + A2:2009 Cranes – Safety – Non-fixed load lifting attachment.

Much more information at www.glgsales.com

GLG Canada Ltd (North America)
 21332 Wilson Street, NOL 1E0
 Delaware, Ontario, Canada
 Phone: 1-855-779-3371

European Head Office
 Soendergaarden 28
 9640 Farsoe, Denmark
 Phone: +45 75 72 72 15

www.glgsales.com

