



MiniMounter

**NEW** Electrically operated panel lifter

– when the  
ceiling is  
a long way up

... one person can now efficiently install plasterboards



**Mountit**<sup>®</sup>  
we do the hard work

# MiniMounter

It's nice to have a high ceiling – but a bit of a problem as well! We all know the old products with swivel wheels or cranks. That's all over – Mountit has developed a world first to replace them!

An electrically operated panel lifter which can grip the panel on the floor from a pallet, or from Mountit's other plasterboard products, without injuring your back or wallet.

Just think: a single person can lift and move a panel from the floor to a ceiling 360 cm high – that's almost 12 feet up – without having to touch the panel at all. What's more, sloping walls are no obstacle!

Powerful, detachable lifting yoke with four grooved grips to grip the panel



The two electrical control boxes for operating the machine are ergonomically designed.

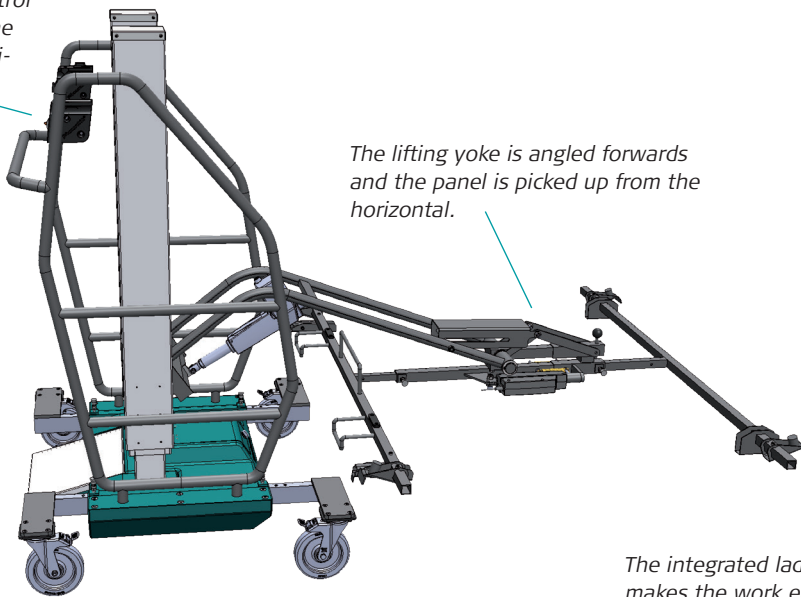

Possibility to angle the lifting yoke for fitting to sloping ceilings

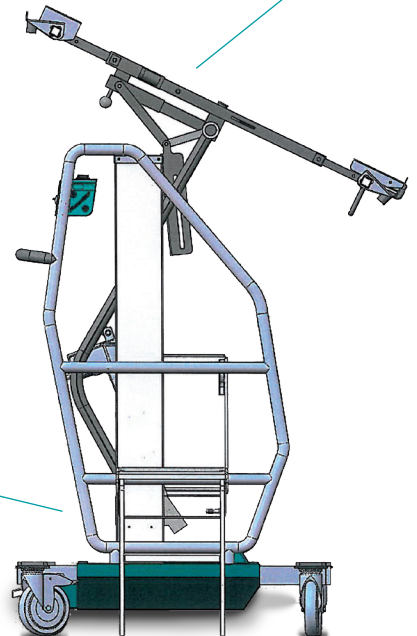

Base with big battery acts as a counterweight.

The four heavy-duty industrial wheels make the machine easy to manoeuvre.

## FAKTA:

Width:	100 cm	Machine power:	24 V
Depth:	70 cm		17 Ah
Min. height:	180 cm		1000 W
Max. height:	360 cm	Charging power:	230 V
Total weight:	125 kg	Lifting capacity:	34 kg
Weight of lifting yoke:	8,3 kg	Max. panel width:	125 cm

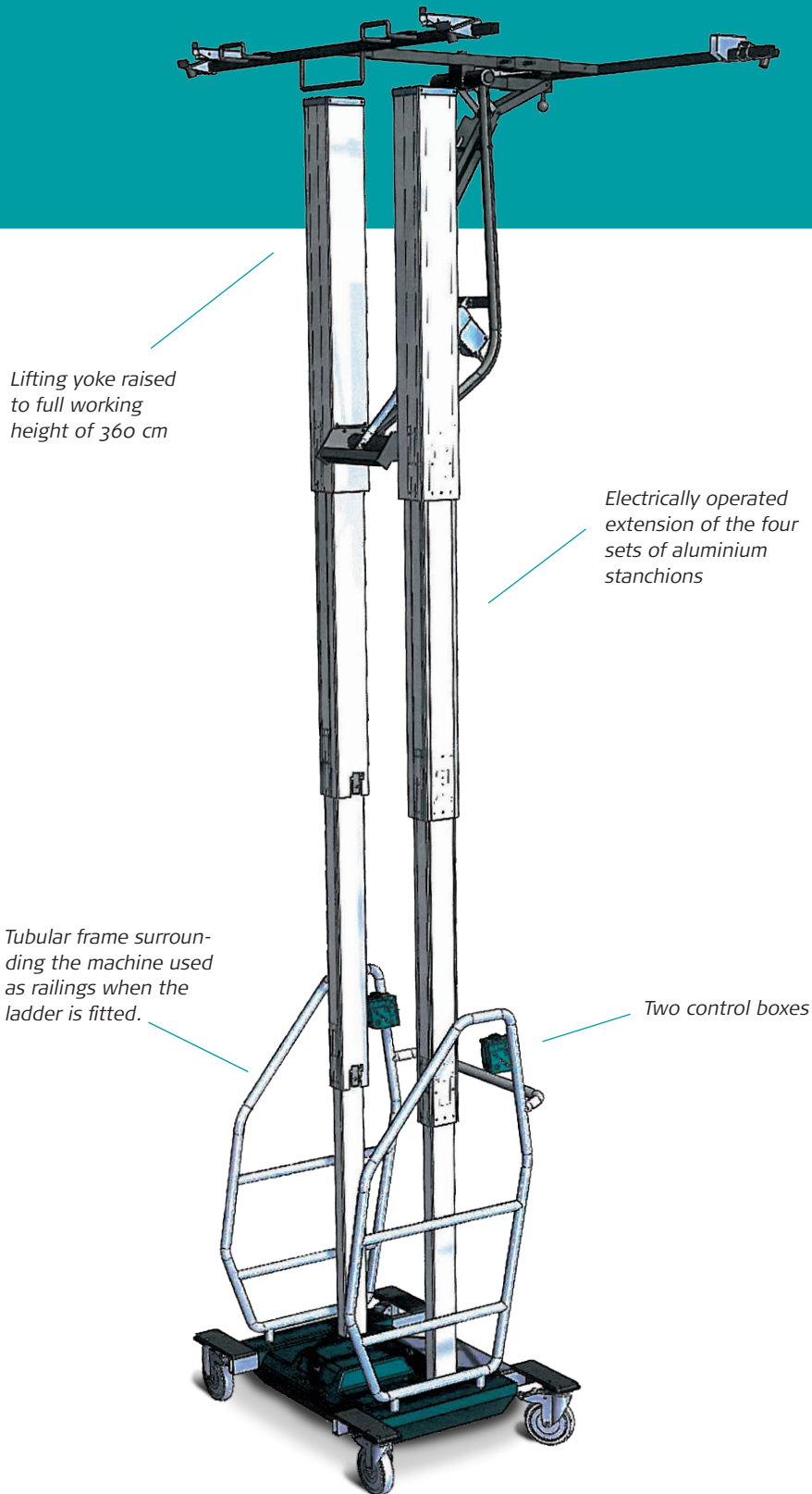

Lifting yoke raised to full working height of 360 cm

Electrically operated extension of the four sets of aluminium stanchions

Tubular frame surrounding the machine used as railings when the ladder is fitted.

Two control boxes

## CAREFULLY CONCEIVED AND TESTED

The MiniMounter is a direct result of the experience acquired by tradesmen during the heavy lifting they do on a daily basis.

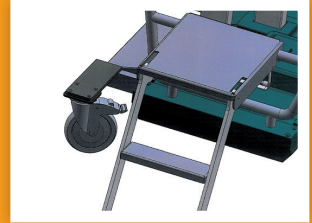

The ladder can be fitted to both sides, allowing the machine to be used as scaffolding. (optional extra)

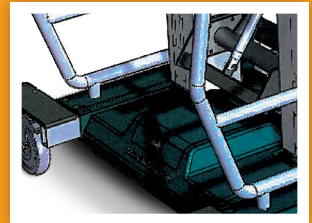

1000 W, 17 Ah battery which can manage a day's work. Charged at 230 V.



All four wheels can be stopped and rotated through 360 degrees. The two front ones can be extended to give optimum stability.



Transport wheels (optional extra)

## DELIVERS EFFICIENCY:

- Can be operated by a single person
- Reaches the ceiling in no time
- Can easily be moved around the work site
- Can also be used for sloping walls



## MiniMounter has been carefully conceived, carefully tested and carefully implemented

After all someone has to hump things around, and that someone is Mountit! We have been brought into the world just to make things easier for you. We have been created by the construction industry for the construction industry. We create solutions which lift, haul, pull and move building materials. We make things easier and more efficient for tradesmen. In short, a healthy working environment also makes good financial sense!



## Are you a Manager, looking to employ the best team?

Get ahead of the game. Health and safety is on the agenda and it will stay that way!

Those businesses which invest in the best technical aids and resources are the ones which attract the best employees and which earn the most money.

Call Mountit and let us help you improve your bottom line.

# Mountit®

www.mountit.dk • info@mountit.dk • +45 75 72 72 15