

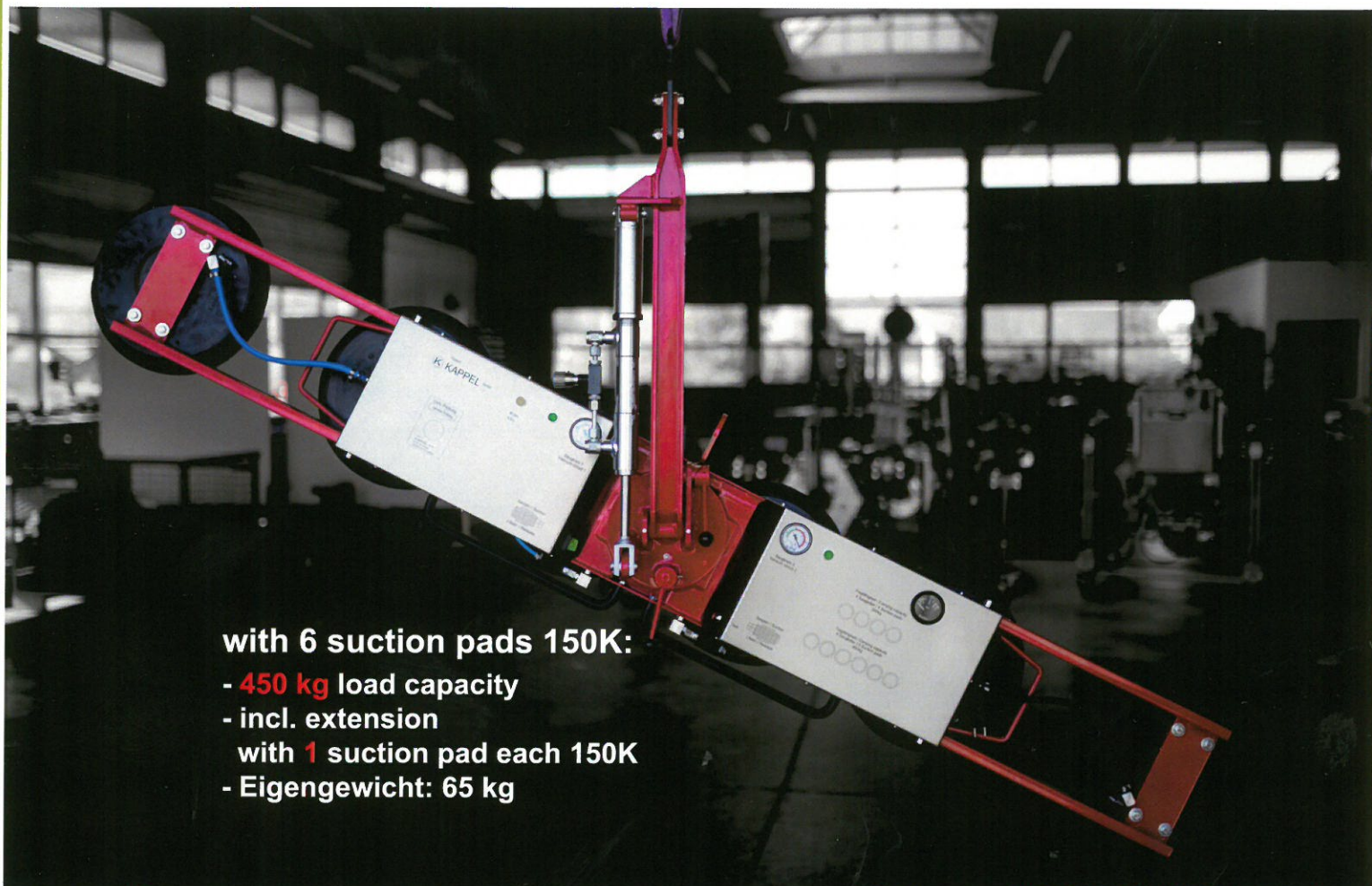

DSKED2 - 12V

In accordance with EN13155 / max.
450 kg load capacity



with 6 suction pads 150K:

- **450 kg** load capacity
- incl. extension
- with **1** suction pad each 150K
- Eigengewicht: 65 kg

Technical data:

- 12 V battery operated
- dual circuit suction system
- warning system
- vacuum tank
- voltage display
- charging device
- manual rotation 360°
- manual tilting 90°

with 4 suction pads 150K:

- **300 kg** load capacity
- dead weight: 45 kg

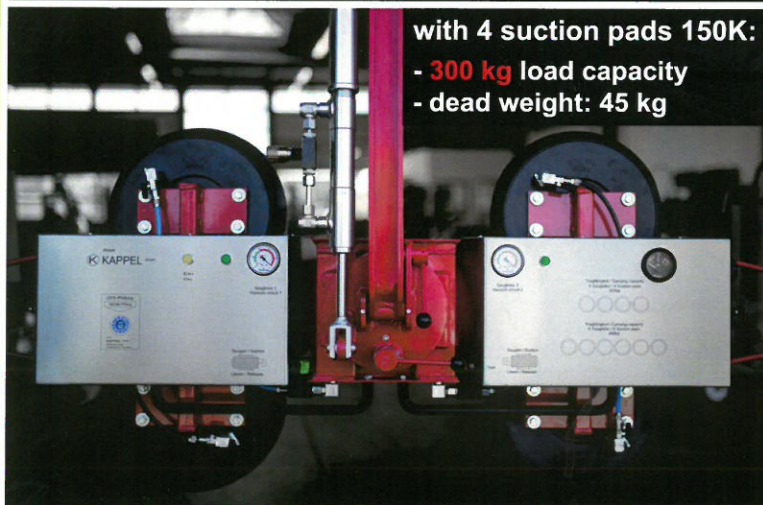

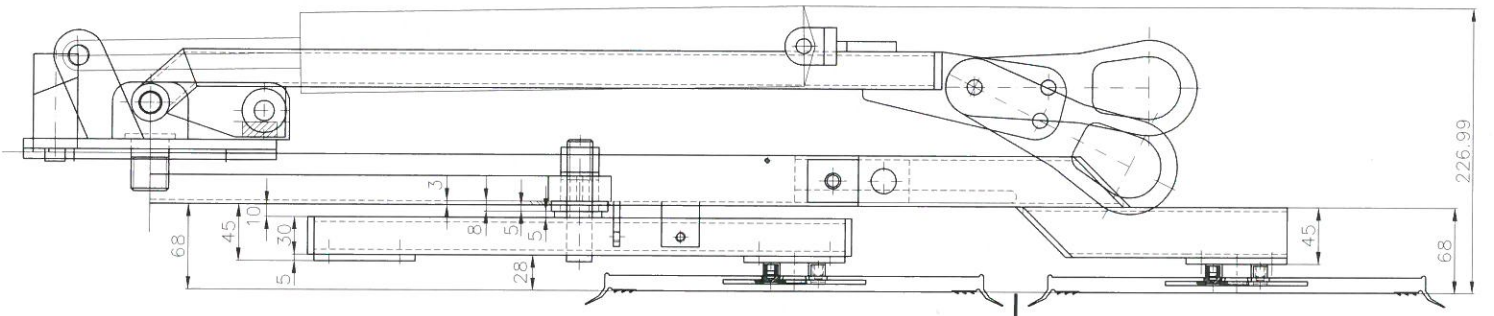
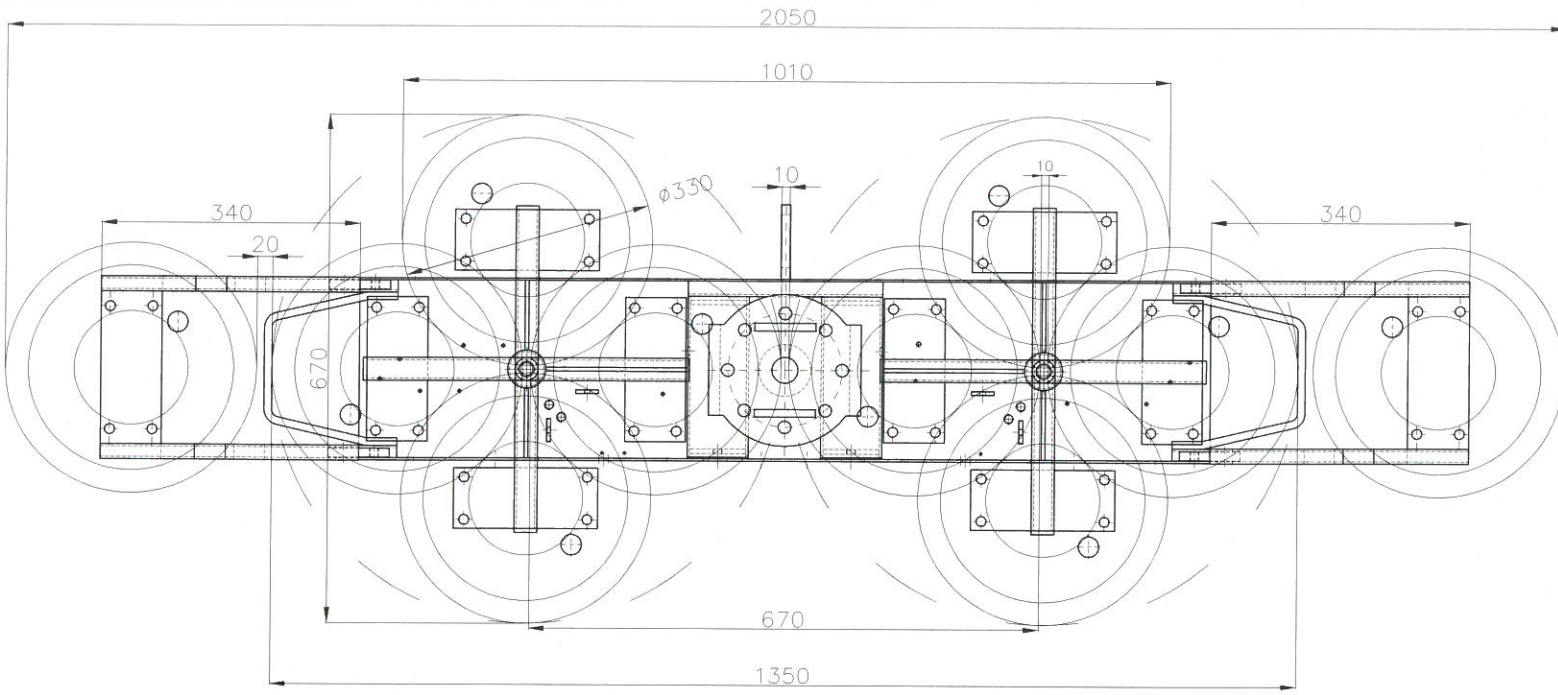

Robert
Kappel
 GmbH

