

PRELIMINARY



 **119** kW (Tier IIIa)
129 kW (Tier IV)

 **40** t

 **30** m

 **MULTICAB**

643E

Telescopic crawler crane

Tier IV emission standards

643E Advanced. The E-Series.



1978: TX10 telescopic crane

What makes up the E-Series

- Over 25 years of experience in construction and building of highly specialized telescopic crawler cranes
- Uncompromisingly high performance in all areas
- Technology that can be mastered: High-quality components without over-engineering
- Long service life and high value stability

Your top benefits:

1

Green Efficiency

Save fuel – reduce operating costs
Work quietly – protect operator and environment



2

Peak performance

Robust boom system – work on an incline of up to 4°
2 equal crane winches – high cable speed

3

Maximum usability **MULTICAB**

multiCab – work in comfort
SENCON – work program selection made easy

4

Flexibility in service

Operate under full load – less space required
Strong undercarriage traction – good off-road capability

5

Easy transport

Telescopic undercarriage – ready to go in no time

6

Maintenance and service made easy

SENNEBOGEN control system – easy error diagnostics
Simple maintenance – clear labeling

7

Consultation and support in your area

3 production sites – 2 subsidiaries
130 sales partners – over 350 service stations

Tier IV emission standards
- Most modern,
powerful engine
- Fuel-efficient
- Clean emissions



643E Technical data, equipment

MACHINE TYPE

Model (type) **643**

ENGINE

Model Cummins diesel engine QSB 4.5
119 kW / 162 hp at 2,200 rpm
 Compliant with Tier 3a emission standards

Cummins diesel engine QSB 4.5
129 kW / 175 hp at 2,500 rpm
 Compliant with Tier 4 emission standards

Direct injection, turbo-charged, charge air cooling, reduced emissions

Cooling Water-cooled

Diesel filter With water separator and heating system

Air filter Dry filter with integrated pre-separator, automatic dust discharge, main element and safety element, contamination indicator

Fuel tank **360 l**

DEF tank **38 l**

Electr. system **24 V**

Batteries **2 x 155 AH** battery disconnect switch

Options

- Low temperature package with engine pre-heating and heated diesel filter for temperatures below -20 °C
- Electric diesel fuel pump

UPPERCARRIAGE

Design Torsion-resistant box design, precision-crafted, steel bushings for boom bearings. Extremely service-friendly design, longitudinal engine

Electrical system Central electrical distributor, battery disconnect switch

Cooling system 3-circuit cooling system with high cooling capacity, electronically regulated fan drive for water, charge air and oil cooler

Safety Rearview and right sideview cameras, LED lighting package

Options

- Additional LED headlights
- Up to 2 additional cameras
- Maritime climate varnishing as corrosion protection
- Low temperature package for use at temperatures below -20 °C

Options

- Automatic central lubrication for boom pivot point, luffing cylinder, slewing ring track and winch drum bearing
- Pinion tooth lubrication for slewing ring

HYDRAULIC SYSTEM

Load sensing/LUDV hydraulic system, electrohydraulic pilot-controlled work functions, load limit sensing control

Pump type Swashplate-type variable-displacement piston pump, load pressure-independent flow distribution for simultaneous, independent control of work functions

Pump control Zero-stroke control, on-demand flow control – the pumps only pump as much oil as will actually be used, pressure purging, load limit sensing control

Operating pressure **max. 330 bar**

Filtration High-performance filtration with long change interval

Hydraulic tank **500 l**

Control system Proportional, precision electrohydraulic actuation of work movements, 2 electric servo joysticks for work functions, including winch motion display via vibration transducer, additional functions via switches and pedals

Safety Hydraulic circuits secured with safety valves
 Pipe fracture safety valve for luffing and telescoping cylinders

Options

- Bio-oil – environmentally friendly
- SENNEBOGEN HydroClean 3 µm hydraulic microfilter
- Electric heater for hydraulic tank for temperatures below -20 °C

SLEWING DRIVE

Gearbox Compact planetary gear with slant-axis hydraulic motor, integrated brake valves

Slewing gear brake Spring-loaded disk brake, pedal for individual braking

Slewing ring Externally geared slewing ring, sealed

Slewing speed **0–2 rpm**, variable

643E Technical data, equipment

CAB <i>MULTICAB</i>	
Cab type	multiCab, can be inclined by 15°
Cab equipment	Flexibly mounted comfortable cab with super sound insulation. All-weather design, all-round glazing in safety glass and large roof window, adjustable windshield. Flexibly mounted comfortable seat, adjustable according to weight and shock-absorbent. Dashboard overview with swiveling steering column. Variable, controllable cab heating with air circulation stage and particle filter, automatic climate control
Options	<ul style="list-style-type: none"> ■ Auxiliary heating system with timer ■ Activated carbon filter for cabs ■ Armored-glass windshield ■ Armored-glass sunroof ■ Protective roof grating ■ FOPS protective roof grating ■ Radio with USB and SD connection, MP3 and Bluetooth function

ATTACHMENTS	
Design	Decades of experience, state-of-the-art computer simulation, maximum stability and service life, oversized and low-maintenance bearing points, sealed special bearing bushes, precision-crafted
Telescopic boom	4-part with pulley head, continuous hydraulic telescoping to 9–30 m
Hoisting winch	Drive using inclined axis hydraulic motor with compact planetary gear, traction 35 kN (40 kN in the 1st position), cable speed 0–95 m/min., cable diameter 14 mm, 160 m cable length.
Safety brake	Spring-loaded disk brake
Crane safety	Next-generation load moment monitoring, straightforward panel displaying all important data through SENCON display, lifting limit switch, cable exit protection, pressure relief valves and pipe fracture safety device with Eventrecorder
Cylinders	Hydraulic cylinders with high-quality sealing and guide elements
Options	<ul style="list-style-type: none"> ■ 6.5 m fly boom, tiltable (0°, 40°), extremely fast and easy setup without auxiliary devices, locked on basic boom when not in use

Options	<ul style="list-style-type: none"> ■ Fly boom extension to 13 m, tiltable (0°, 40°) ■ Wind movement display using vibrating joystick ■ Auxiliary jib, 3.5 t load capacity, 1-strand ■ 2nd crane winch: traction 35 kN (4th position), cable speed 0–95 m/min, cable diameter 14 mm, 130 m cable length ■ Additional load charts accepted for 2°/4° incline position ■ 7.5 kW electrohydraulic emergency unit ■ Remote radio control ■ Working range restriction
---------	---

UNDERCARRIAGE	
Design	T41/380 crawler undercarriage with hydraulically extendable track width. Stable welded construction.
Drive	Hydraulic travel drive per chassis side, adjustable hydraulic drive motors
Parking brake	Spring-loaded, hydraulically ventilated disk brake
Traveling gear	700 mm, 3-grouser base plates, maintenance-free tractor drive
Speed	0–2.7 km/h
Options	Available base plate types: <ul style="list-style-type: none"> ■ 800 mm 3-grouser base plates ■ 900 mm 3-grouser base plates ■ 700 mm flat base plates

OPERATING WEIGHT	
Mass	Approx. 42 t With 30 m telescopic boom, 13 m fly boom, 35 t hook, 700 mm 3-grouser base plates, 2 hoisting winches, hydraulically telescoping undercarriage, 7 t ballast, 4 t undercarriage ballast
Notice	The operating weight varies according to model type.



643E Crane equipment



30 m main boom (HA)

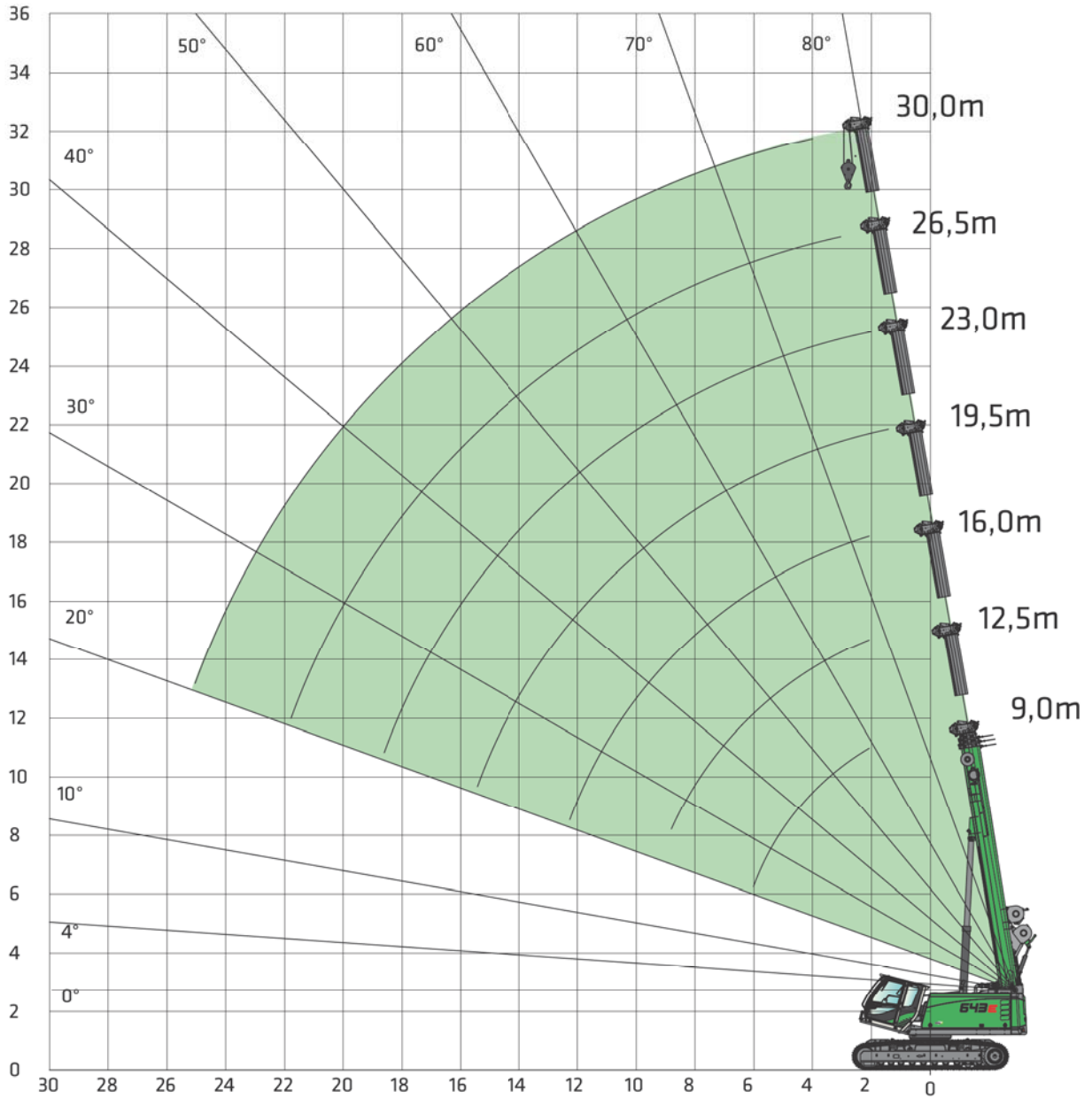

Hook

Capacity	Weight	Number of strands								
		9	8	7	6	5	4	3	2	1
32 t 4-pulley	300 kg	31,500 kg	28,000 kg	24,500 kg	21,000 kg	17,500 kg	14,000 kg	10,500 kg	7,000 kg	3,500 kg
25 t 3-pulley	220 kg			24,500 kg	21,000 kg	17,500 kg	14,000 kg	10,500 kg	7,000 kg	3,500 kg
4 t	40 kg									3,500 kg

643E Load ratings



30 m main boom (HA)

	Boom length [m]																				
	9.0			12.5			16.0			19.5			23.0			26.5			30.0		
Counterweight [t]																					
Undercarriage ballast [t]																					
Undercarriage track width [m]																					
Outreach [m]																					
2.0	40.0*	40.0*	40.0*																		
3.0	35.0	35.0	33.0	20.0	20.0	20.0	15.0	15.0	15.0	14.0	14.0	14.0	11.0	11.0	11.0	8.9	8.9	8.9	5.0	5.0	5.0
4.0	30.2	27.7	20.2	20.0	20.0	19.9	15.0	15.0	15.0	14.0	14.0	14.0	11.0	11.0	11.0	8.9	8.9	8.9	5.0	5.0	5.0
5.0	25.5	18.9	14.2	20.0	18.7	14.0	15.0	15.0	13.9	13.3	13.3	13.3	11.0	11.0	11.0	8.6	8.6	8.6	5.0	5.0	5.0
6.0	18.0	14.1	10.7	18.5	13.9	10.5	14.9	13.8	10.5	12.0	12.0	10.9	10.3	10.3	10.3	8.3	8.3	8.3	5.0	5.0	5.0
7.0	11.8/6.2	13.4/6.2	10.2/6.2	14.3	10.9	8.3	13.2	10.8	8.2	10.9	10.9	8.6	9.5	9.5	8.9	7.8	7.8	7.8	5.0	5.0	5.0
8.0				11.5	8.8	6.7	11.4	8.7	6.6	9.8	9.1	7.0	8.7	8.7	7.3	7.4	7.4	7.4	5.0	5.0	5.0
9.0				9.5	7.3	5.5	9.4	7.2	5.4	9.0	7.6	5.8	7.9	7.8	6.1	6.9	6.9	6.2	5.0	5.0	5.0
10.0				7.5/9.6	6.5/9.6	4.9/9.6	8.0	6.1	4.5	8.3	6.4	4.9	7.1	6.7	5.1	6.4	6.4	5.3	5.0	5.0	5.0
11.0							6.8	5.1	3.7	7.2	5.5	4.1	6.5	5.7	4.4	5.9	5.9	4.5	5.0	5.0	4.7
12.0							5.9	4.4	3.1	6.2	4.7	3.5	5.9	5.0	3.7	5.5	5.2	3.9	5.0	5.0	4.1
13.0							5.0	3.7	2.6	5.4	4.1	3.0	5.5	4.3	3.2	5.1	4.5	3.4	4.7	4.7	3.5
14.0										4.8	3.6	2.6	5.0	3.8	2.8	4.8	4.0	3.0	4.4	4.1	3.1
15.0										4.2	3.1	2.2	4.5	3.3	2.4	4.5	3.5	2.6	4.1	3.7	2.7
16.0										3.7	2.7	1.9	4.0	2.9	2.1	4.2	3.1	2.3	3.8	3.3	2.4
17.0										3.5/16.6	2.5/16.6	1.7/16.6	3.6	2.6	1.8	3.7	2.8	2.0	3.6	2.9	2.1
18.0													3.2	2.3	1.6	3.4	2.5	1.7	3.3	2.6	1.9
19.0													2.9	2.0	1.3	3.0	2.2	1.5	3.1	2.3	1.6
20.0													2.6	1.8	1.1	2.7	2.0	1.3	2.9	2.1	1.4
21.0													2.5/20.1	1.8/20.1	1.1/20.1	2.5	1.8	1.1	2.6	1.9	1.3
22.0																2.2	1.6	1.0	2.4	1.7	1.1
23.0																1.9/23.6	1.3/23.6	0.7/23.6	2.2	1.5	0.9
24.0																			2.0	1.3	0.8
25.0																			1.8	1.2	0.7
26.0																			1.6	1.1	0.6
27.0	Table no.: 643R-30.0/75/1977/7.0/08.06																				
28.0	Table no.: 643R-30.0/75/1677/7.0/02.08																				
28.0	Table no.: 643R-30.0/75/1227/7.0/08.06																				
Number of strands	10	10	1	6	6	1	5	5	1	4	4	1	4	4	1	3	3	1	2	2	1
I	0%			50%			100%			100%			100%			100%					
II	0%			0%			0%			25%			50%			75%			100%		
III	0%			0%			0%			25%			50%			75%			100%		
Load capacity reduction	570			420			330			280			240			210			180		

643E Crane equipment



6.5 m or 13 m fly boom (SA)

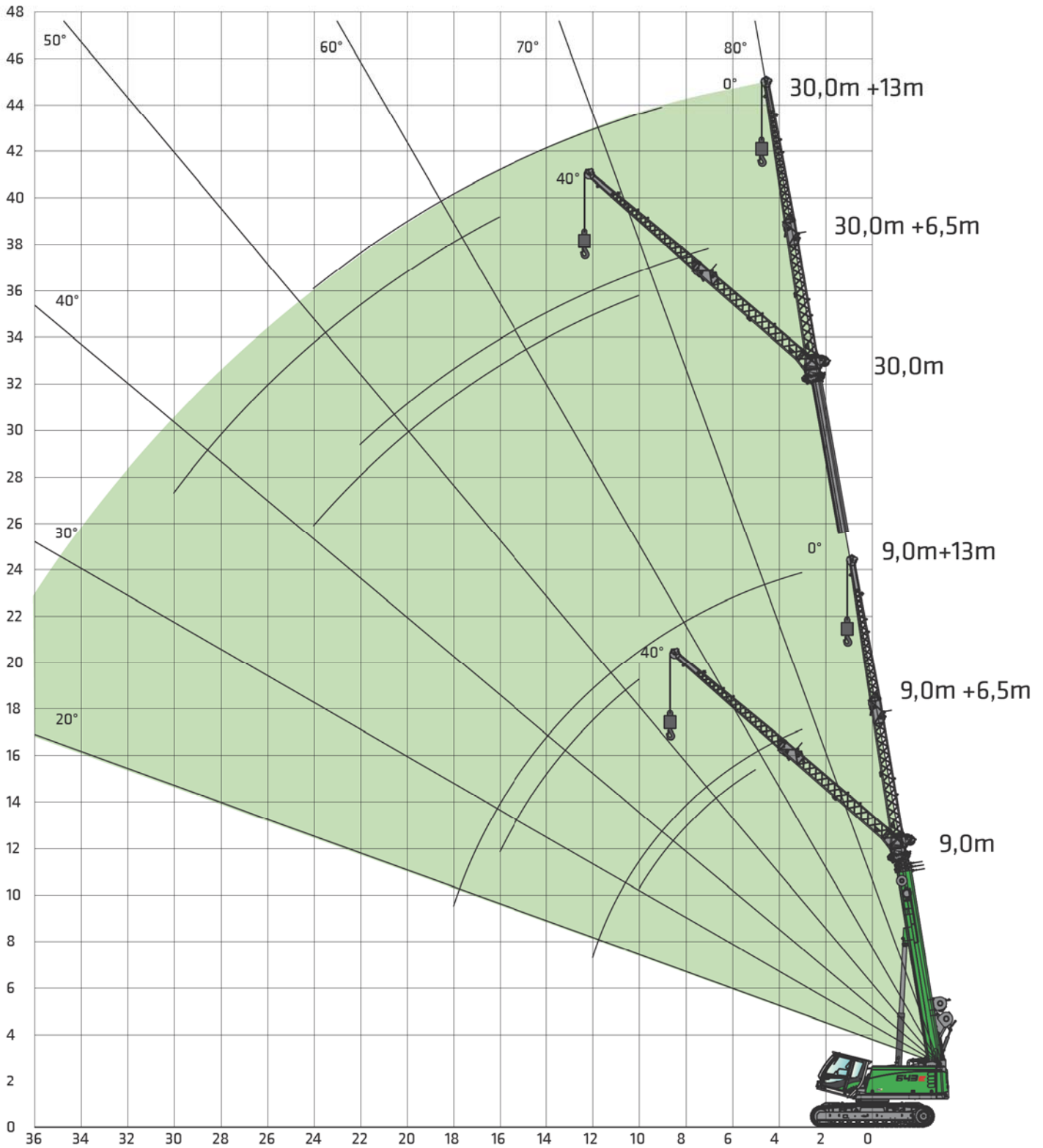

643E Load ratings



6.5 m fly boom (SA)

7.0 t	4.0 t	Telescopic boom length [m]							
		9.0		16.0		23.0		30.0	
3.8 m		0°	40°	0°	40°	0°	40°	0°	40°
Outreach [m]									
2.0									
3.0	6.0			6.0					
4.0	6.0			6.0					
5.0	5.5	3.5		6.0		6.0			
6.0	4.9	3.3		6.0	3.6	6.0			
7.0	4.4	3.1		5.9	3.4	6.0		3.5	
8.0	4.0	2.9		5.4	3.3	5.9	3.4	3.5	
9.0	3.7	2.8		5.0	3.2	5.6	3.3	3.5	
10.0	3.4	2.7		4.6	3.1	5.3	3.2	3.5	3.2
11.0	3.1			4.3	3.0	5.0	3.2	3.5	3.0
12.0	2.8			4.1	2.8	4.7	3.1	3.5	2.9
13.0				3.9	2.8	4.4	3.0	3.5	2.8
14.0				3.7	2.8	4.2	2.9	3.3	2.7
15.0				3.5		3.9	2.9	3.0	2.5
16.0				3.3		3.7	2.8	2.8	2.4
18.0				2.9		3.3	2.7	2.4	2.3
20.0						2.7	2.6	2.1	2.1
22.0						2.2		1.9	1.9
24.0						1.7		1.8	1.7
26.0						1.4		1.5	1.6
28.0								1.2	
30.0								0.9	
32.0								0.7	
34.0									
36.0									
38.0	Table no.: 643R-30.0/75/1977/7.0/08.06 SA6.5								
Number of	2	1	2	1	2	1	2	1	
I	0%		100%		100%		100%		
II	0%		0%		50%		100%		
III	0%		0%		50%		100%		

643E Load ratings



13 m fly boom (SA)

7.0 t	4.0 t	Telescopic boom length [m]							
		9.0		16.0		23.0		30.0	
3.8 m		0°	40°	0°	40°	0°	40°	0°	40°
Outreach [m]									
2.0									
3.0	3.0								
4.0	3.0								
5.0	3.0			3.0					
6.0	3.0			3.0					
7.0	2.9			3.0		3.0			
8.0	2.6			3.0		3.0			
9.0	2.3			2.9		3.0		2.0	
10.0	2.1	1.6		2.7		2.9		2.0	
11.0	2.0	1.5		2.5		2.7		2.0	
12.0	1.8	1.4		2.4	1.5	2.6		2.0	
13.0	1.7	1.4		2.2	1.5	2.5		2.0	
14.0	1.6	1.3		2.1	1.5	2.4	1.5	2.0	
15.0	1.6	1.3		2.0	1.4	2.3	1.5	2.0	
16.0	1.5	1.3		1.9	1.4	2.2	1.4	2.0	1.5
18.0	1.1			1.7	1.3	2.0	1.4	2.0	1.4
20.0				1.6	1.3	1.8	1.3	1.9	1.4
22.0				1.4		1.7	1.3	1.7	1.3
24.0				1.3		1.6	1.3	1.6	1.3
26.0						1.4	1.3	1.4	1.2
28.0						1.3		1.3	1.2
30.0						1.3		1.2	1.1
32.0						1.1		1.1	1.1
34.0								0.9	
36.0								0.7	
38.0	Table no.: 643R-30.0/75/1977/7.0/08.06 SA13.0							0.6	
Number of	1	1	1	1	1	1	1	1	1
I	0%		100%		100%		100%		
II	0%		0%		50%		100%		
III	0%		0%		50%		100%		

643E Load ratings



Auxiliary jib (HA-S)

	Boom length [m]													
	9.0		12.5		16.0		19.5		23.0		26.5		30.0	
Counterweight [t]	7.0	7.0	7.0	7.0	7.0	7.0	7.0	7.0	7.0	7.0	7.0	7.0	7.0	7.0
Undercarriage ballast [t]	4.0	4.0	4.0	4.0	4.0	4.0	4.0	4.0	4.0	4.0	4.0	4.0	4.0	4.0
Undercarriage track width [m]	3.8	2.3	3.8	2.3	3.8	2.3	3.8	2.3	3.8	2.3	3.8	2.3	3.8	2.3
Outreach [m]														
2.0														
3.0	3.5	3.5	3.5	3.5	3.5	3.5	3.5	3.5	3.5	3.5	3.5	3.5	3.5 / 3.5	3.5 / 3.5
4.0	3.5	3.5	3.5	3.5	3.5	3.5	3.5	3.5	3.5	3.5	3.5	3.5	3.5	3.5
5.0	3.5	3.5	3.5	3.5	3.5	3.5	3.5	3.5	3.5	3.5	3.5	3.5	3.5	3.5
6.0	3.5	3.5	3.5	3.5	3.5	3.5	3.5	3.5	3.5	3.5	3.5	3.5	3.5	3.5
7.0	3.5 / 6.7	3.5 / 6.7	3.5	3.5	3.5	3.5	3.5	3.5	3.5	3.5	3.5	3.5	3.5	3.5
8.0			3.5	3.5	3.5	3.5	3.5	3.5	3.5	3.5	3.5	3.5	3.5	3.5
9.0			3.5	3.5	3.5	3.5	3.5	3.5	3.5	3.5	3.5	3.5	3.5	3.5
10.0			3.5	3.5	3.5	3.5	3.5	3.5	3.5	3.5	3.5	3.5	3.5	3.5
11.0			3.5 / 10.2	3.5 / 10.2	3.5	3.5	3.5	3.5	3.5	3.5	3.5	3.5	3.5	3.5
12.0					3.5	3.0	3.5	3.4	3.5	3.5	3.5	3.5	3.5	3.5
13.0					3.5	2.5	3.5	2.9	3.5	3.1	3.5	3.3	3.5	3.4
14.0					3.5 / 13.7	2.1 / 13.7	3.5	2.5	3.5	2.7	3.5	2.9	3.5	3.0
15.0							3.5	2.1	3.5	2.3	3.5	2.5	3.5	2.6
16.0							3.5	1.8	3.5	2.0	3.5	2.2	3.5	2.3
17.0							3.1	1.5	3.5	1.7	3.5	1.9	3.5	2.0
18.0							3.0 / 17.2	1.4 / 17.2	3.1	1.5	3.3	1.6	3.2	1.8
19.0									2.8	1.2	2.9	1.4	3.0	1.5
20.0									2.5	1.0	2.6	1.2	2.8	1.3
21.0									2.2 / 20.7	0.8 / 20.7	2.4	1.0	2.5	1.2
22.0											2.1	0.9	2.3	1.0
23.0											1.8	0.7	2.1	0.8
24.0											1.7 / 24.2	0.6 / 24.2	1.9	0.7
25.0													1.7	0.6
26.0													1.5	0.5
27.0	Table no.: 643R-30.0/75/1977/7.0/12.16 HA-S												1.4	
28.0	Table no.: 643R-30.0/75/1227/7.0/12.16 HA-S												1.4 / 27.1	
Number of strands	1	1	1	1	1	1	1	1	1	1	1	1	1	1
I	0%		50%		100%		100%		100%		100%		100%	
II	0%		0%		0%		25%		50%		75%		100%	
III	0%		0%		0%		25%		50%		75%		0%	
Load capacity reduction [kg]	570		420		330		280		240		210		180	

643E Load capacity programs

		Main boom HA			Auxiliary jib HA-S		6.5 m fly boom (SA)			Fly boom SA 13 m		
Counterweight [t]	Undercarriage ballast [t]											
		Undercarriage track width			Undercarriage track width		Undercarriage track width			Undercarriage track width		
		360° 	360° 	360° 	360° 	360° 	360° 	-	-	360° 	-	-

Note:

1. Specified load ratings only apply when machine is level ($\pm 0.3^\circ$) and stable.
2. Load ratings are specified in tons and apply to 360 degrees.
3. Load ratings are in accordance with DIN 15019.2 and ISO 4305.
4. The weight of the load handling devices (e.g., hook, suspension gear) must be subtracted from the load ratings.
5. Load ratings must be limited or reduced when conditions are unfavorable, such as soft or uneven ground, slopes, wind, lateral loads, swinging loads, jerking or sudden stopping of load, operator inexperience, driving with load.
6. Permissible rope winch per strand in crane mode for cable diameter 14 mm – 3,500 kg.
7. Specified load ratings are for reference only. The currently valid load ratings can be found in the tables in the operating manual.
8. The values marked * only apply in the case of special equipment.
9. Optional load capacities are also available for a 4° incline position.

643E Fly boom



Fly boom variants

- 6.5 m fly boom*
Max. 2-strand, possible offset angle 0°/40°
- 13 m fly boom*
with 6.5 m extension,
1-strand, offset angle 0°/40°
- Auxiliary jib
3.5 t load capacity, 1-strand

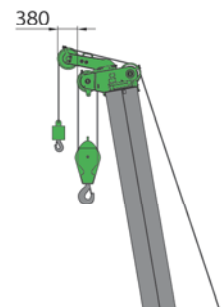

643E Transport dimensions and weights

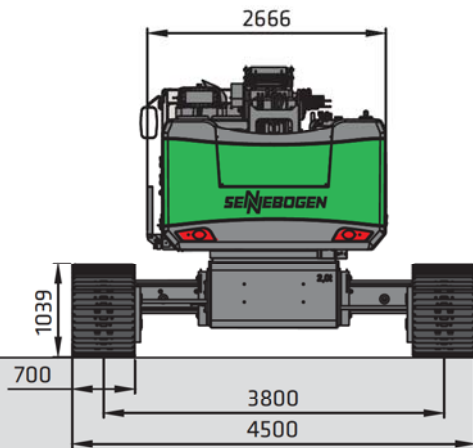

Base plates	Min. transport width
700 mm	3000 mm
800 mm	3300 mm
900 mm	3400 mm

643 with T41/380 undercarriage and 700 mm 3-grouser base plates

Operating weight: approx. 42 t

(with 13 m fly boom, 2 hoisting winches, 7.0 t counterweight, 4.0 t undercarriage ballast and 35 t hook)

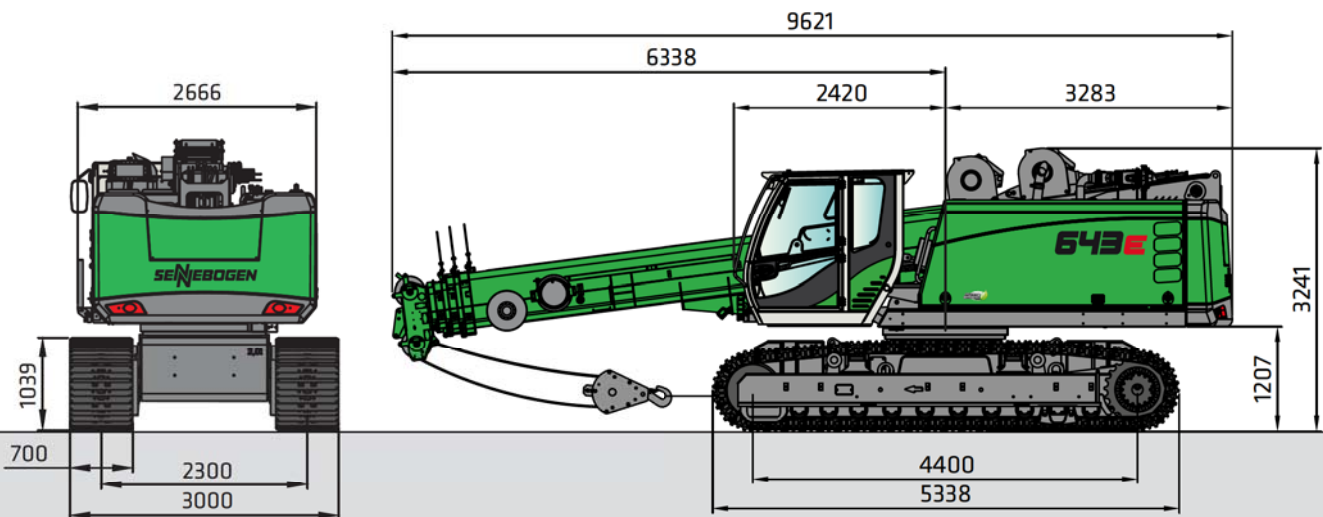

Transport weight: approx. 38,000 kg (13 m fly boom, 2 hoisting winches, without undercarriage ballast)

approx. 42,000 kg (13 m fly boom, 2 hoisting winches, with undercarriage ballast)

643E Transport dimensions and weights

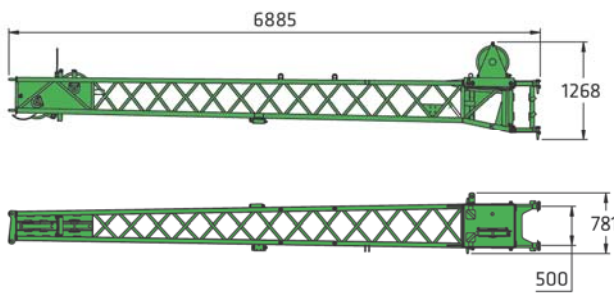

6.5 m fly boom

600 kg

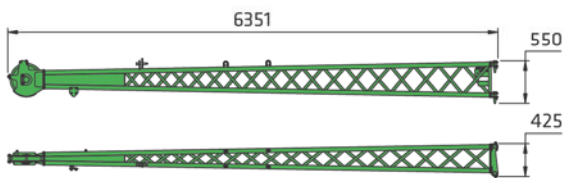

6.5 m fly boom extension

250 kg

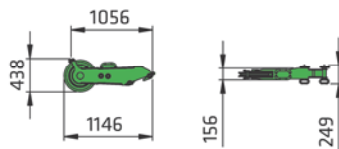

Auxiliary jib

50 kg

643E Notes

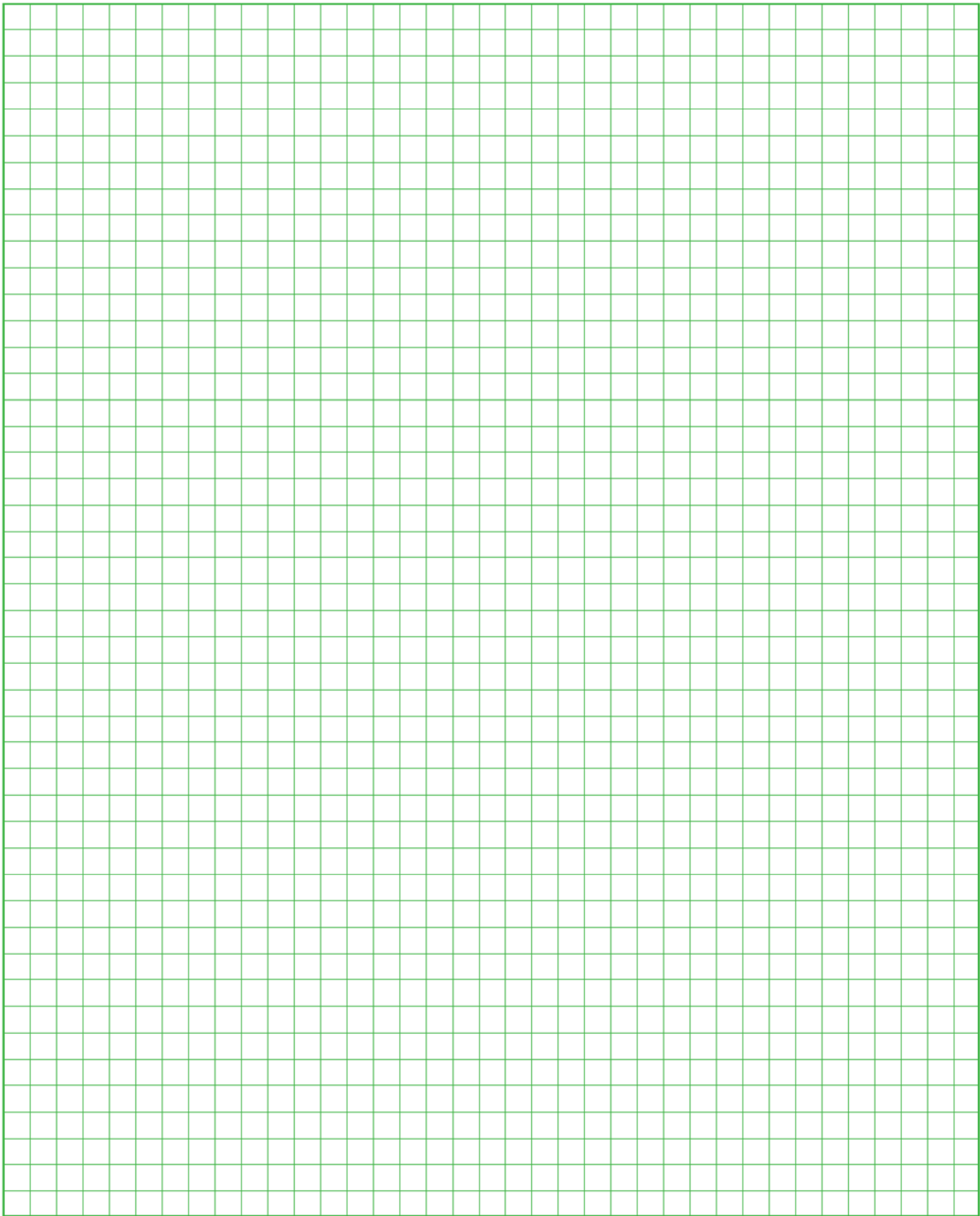

643E

R

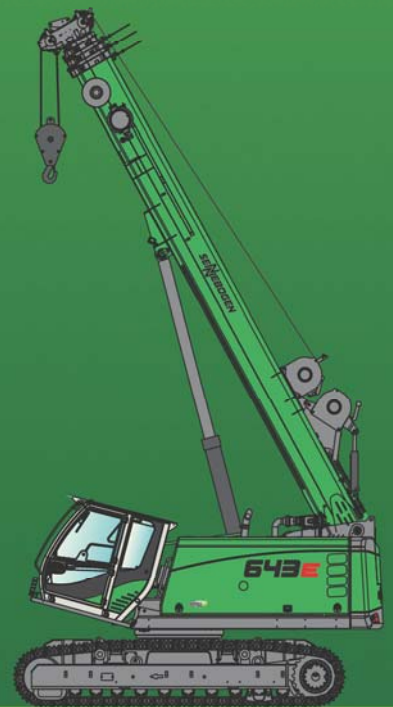

This catalog describes machine models, scopes of equipment of individual models, and configuration options (standard equipment and optional equipment) of the machines supplied by SENNEBOGEN Maschinenfabrik GmbH. Machine illustrations can contain optional equipment and supplemental equipment. Actual equipment may vary depending on the country to which the machines are delivered, especially in regard to standard and optional equipment. All product designations used may be trademarks of SENNEBOGEN Maschinenfabrik GmbH or other supplying companies, and any use by third parties for their own purposes may violate the rights of the owners.

Please contact your local SENNEBOGEN sales partner for information concerning the equipment variants offered. Requested performance characteristics are only binding if they are expressly stipulated upon conclusion of the contract. Delivery options and technical features are subject to change. Errors and omissions excepted. Equipment is subject to change, and rights of advancement are reserved. © SENNEBOGEN Maschinenfabrik GmbH, Straubing, Germany. Reproduction in whole or in part only with written consent of SENNEBOGEN Maschinenfabrik GmbH, Straubing, Germany.

SENNEBOGEN

SENNEBOGEN
Maschinenfabrik GmbH
Sennebogenstraße 10
94315 Straubing, Germany

Tel. +49 9421 540-144/146
Fax +49 9421 43 882
marketing@sennebogen.de

Order no. 295155
643R-E-081710

GO FOR GREEN

 www.sennebogen.com